

INSTALLATION METHOD FOR MAIN STUD KITS

Part Number: 155-5401 & 155-5421 Application: Ford 390-428 cid FE Series

Note: This kit requires machining on the No.5 rear cap "only" due to clearance issues with the oil pan (see instructions shown below).

1. To ensure proper thread engagement and accurate torque readings, clean **ALL** threads in the block. Chase the threads if necessary with ARP Thread Chaser, part number 911-0005 (1/2 -13).
2. Clean and inspect all hardware prior to installation. Look for obvious defects or shipping damages, plus proper fit, length and dimension.
3. Screw the studs into the block "HAND TIGHT ONLY". **Note 1:** The 4.375 in. long studs are installed in the No. 1-4 mains and the "shorter" 3.700 in. long studs are installed in the No. 5 main. **Note 2: LOCTITE MAY BE USED IF A PERMANENT MOUNTING OF THE STUDS IS PREFERRED.**
4. Install the main caps and check for binding or misalignment.
5. Lubricate the stud threads, nuts and the washers with ARP ULTRA-TORQUE FASTENER ASSEMBLY LUBRICANT. Then install the washers and the nuts onto the studs and tighten them hand tight. **ARP recommends using the ARP ULTRA-TORQUE FASTENER ASSEMBLY LUBRICANT that is provided with each kit as opposed to motor oil. This is due to higher friction on the studs and bolts as well as inconsistencies in the clamping force of the fasteners when motor oil or other low quality lubricants are used.**

PRELOAD (TORQUE) RECOMMENDATIONS

6. Following the manufacturers recommended torque sequence tighten the nuts in three equal steps to 110 ft lbs with ARP ULTRA-TORQUE FASTENER ASSEMBLY LUBRICANT.

FOOTNOTE: When changing from factory fasteners to high strength fasteners, clamping force and tolerances will change, therefore it will be necessary to check the main bearing bores for proper size and out of round condition after installation of the studs and align hone the cylinder block if necessary. The main bores should always be align honed using the same fasteners and lubricant which will be installed during final engine assembly at the recommended preload.

Bolt Torque Sequence & Machining Instructions

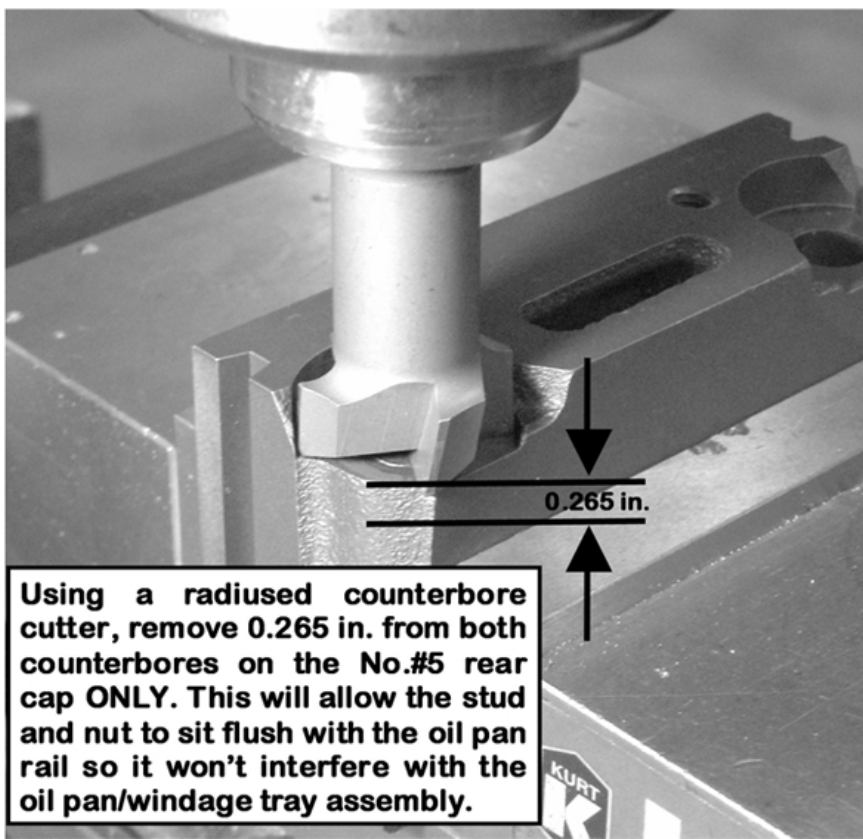
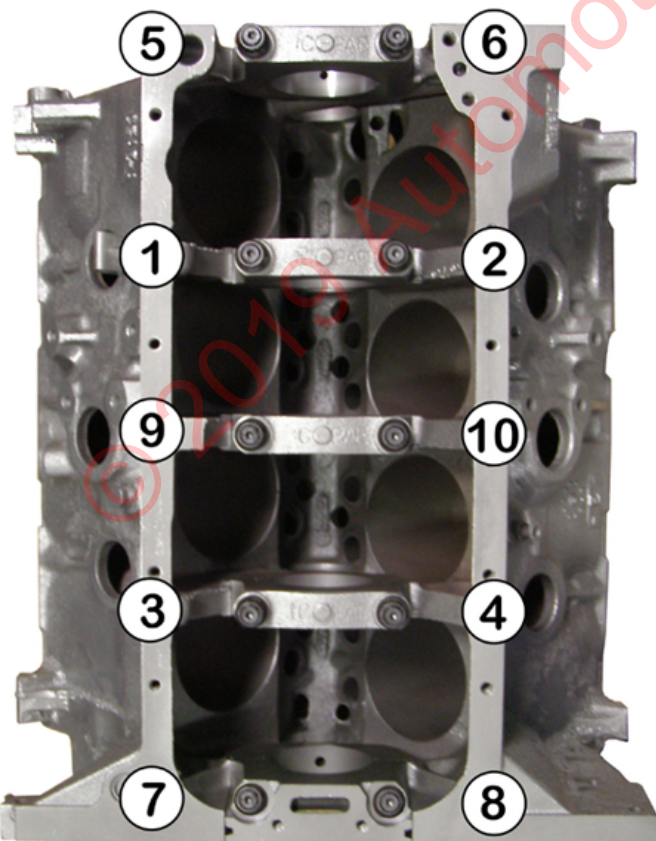

Using a radiused counterbore cutter, remove 0.265 in. from both counterbores on the No.#5 rear cap ONLY. This will allow the stud and nut to sit flush with the oil pan rail so it won't interfere with the oil pan/windage tray assembly.